

Memorial's technology transfer and commercialization.

IP BASICS – NL SUPPORT

ideas to
opportunities.



tech transfer @ MUN.

- **Supporting the development of IP**
- **IP Education**
- **Informing on IP rights**
- **Commercializing the outcomes of academic research:**
 - Collaborations with industry
 - Licensing IP
 - Start-ups spinning out of a project (licensing IP)



we help students.

- Education on IP
- Connections with resources
- Verify whether IP is encumbered



what is intellectual property?

Literary artistic and scientific works; performances of performing artists, phonograms, and broadcasts; inventions in all fields of human endeavor; scientific discoveries; industrial designs; trademarks, service marks, and commercial names and designations; protection against unfair competition; and “all other rights resulting from intellectual activity in the industrial, scientific, literary or artistic fields.” (Convention Establishing the World Intellectual

Property Organization, Signed at Stockholm on July 14, 1967; Article 2, § viii)

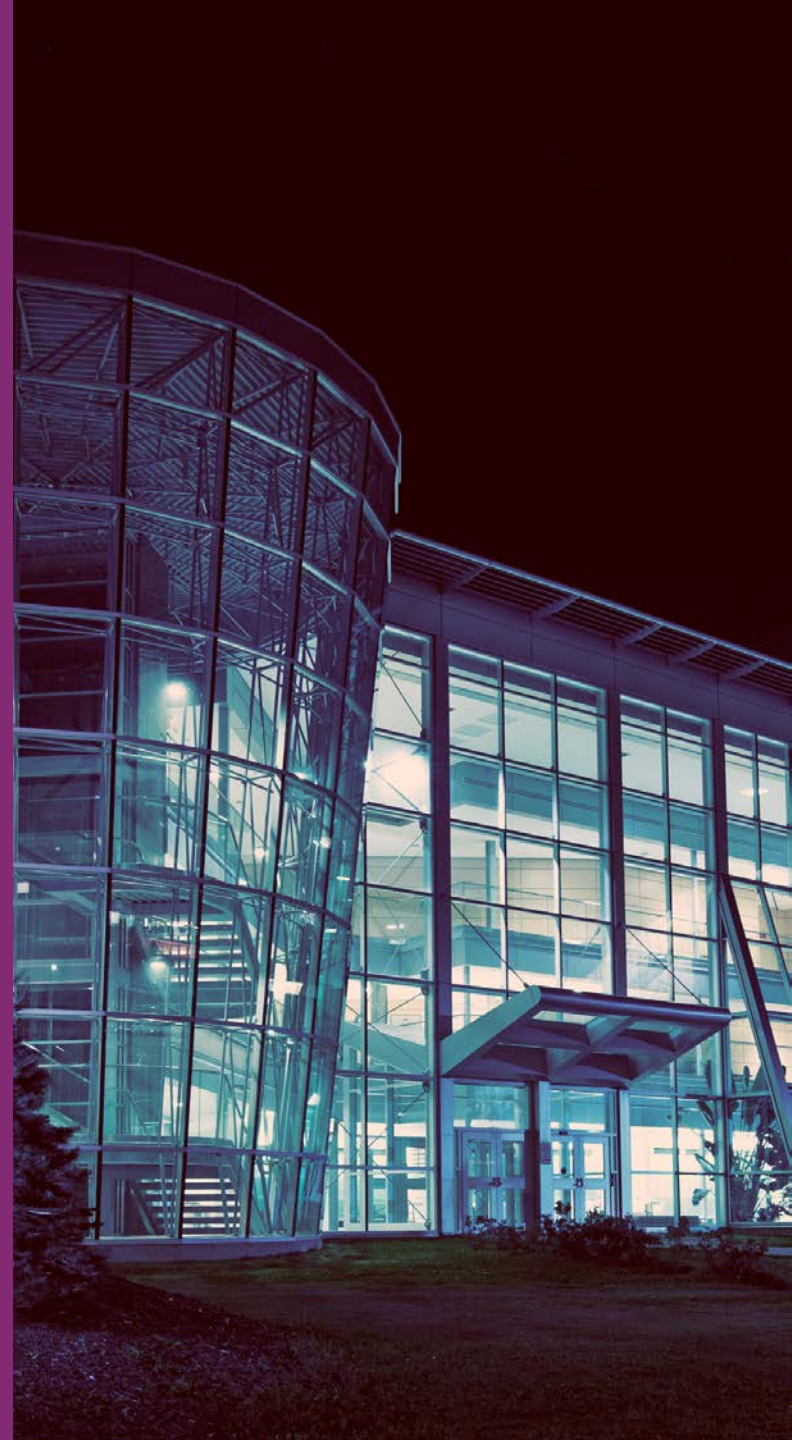

put simply.

**An intangible creation of the mind,
expressed or translated into a
tangible form, that can be
legally protected.**

disclosures.



what should be disclosed?

**New & useful art, process, machine
or composition of matter**

Software, research data or tool

**Proprietary information or know-
how**

Invention disclosure form answers.

Invention and inventorship

Funding sources

Licensing candidates

contents.

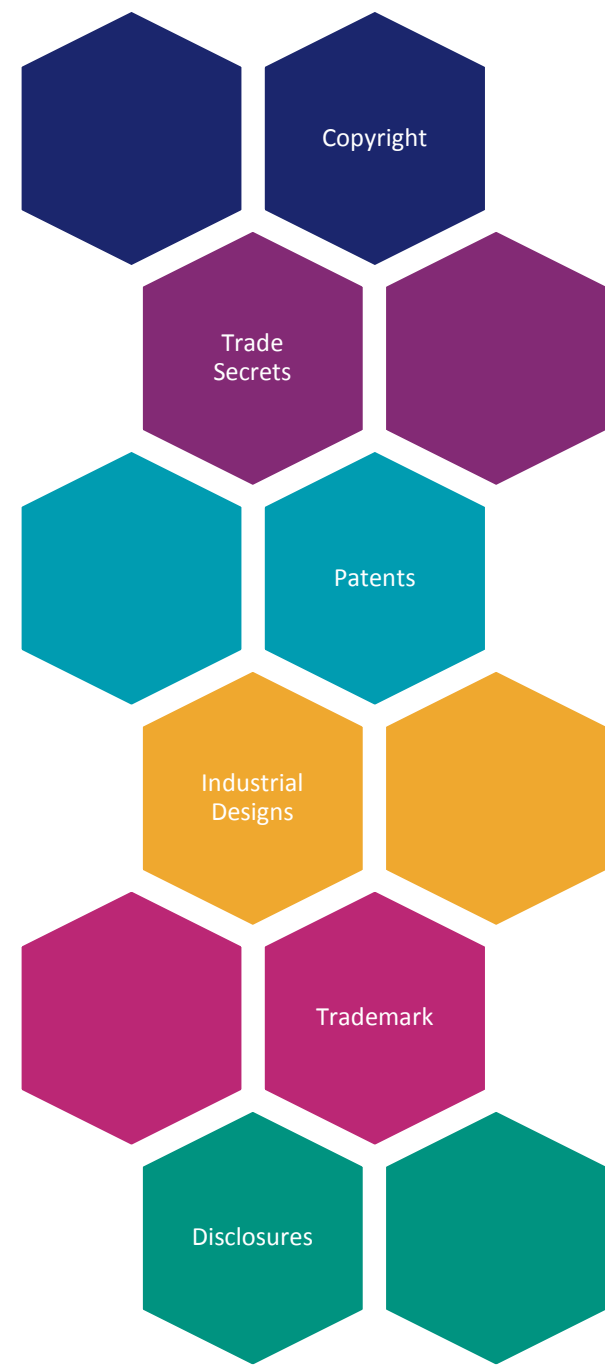

copyright ©.

**protecting
the work of
the human
intellect.**

NOT ideas

protects WORKS

**e.g. writings, music, and works of
the fine arts**

how to secure a copyright?

It is automatic when the work is tangible.

Register a copyright

Certificate of registration can be used in court as evidence that you own the protected work.

timeline.

50 Years A.D.

Life of the creator (up to the end of the year in which the creator dies) and for 50 years following that calendar year. The protection will expire on December 31 of the 50th year after the author dies.

infringement examples.



Tattoo Artist, S. Victor Whitmill vs. Hangover 2 (Warner Brothers) (settled)



other considerations.

- Computer Programs
- Creative Commons
- Open Source



trade secrets.

why should you keep it a secret?

- **Ensure an invention or design is not disclosed before applying for a patent or industrial design**
- **If the invention has a short lifespan or is difficult to reverse engineer**
- **If you cannot protect through other intellectual property rights**

examples.

- **Coca Cola's formula – guarded for over 100 years**
- **Google's search algorithm**
- **Kentucky Fried Chicken recipe**
- **WD-40**
- **McDonald's Big Mac Sauce**

how can I keep a trade secret?

- **Non-disclosure or confidentiality agreements**
- **Confidentiality clauses**
- **Encryption**
- **Password Protection**
- **Lock and Key**

Trade secrets can last forever provided the information remains a secret.

patents.

what is a patent?

Legal Document

Prevents people from using your invention

Exclusive right to your invention for up to 20 years

what is patentable?

Novel

Useful

Non-obvious

what is patentable?

- **Products (devices)**
- **Composition (materials)**
- **Machines**
- **Processes (methods)**
- **Improvements to any of these**

examples.

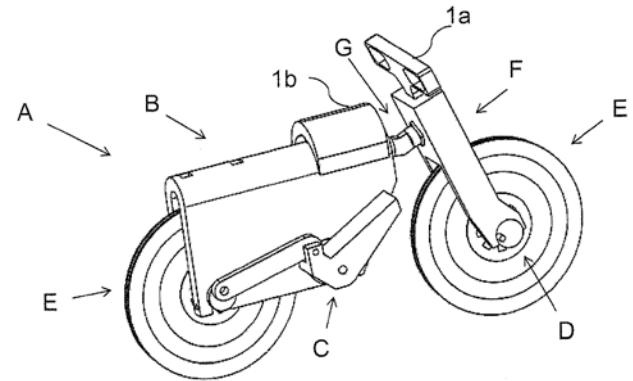

Recyclable cardboard bicycle

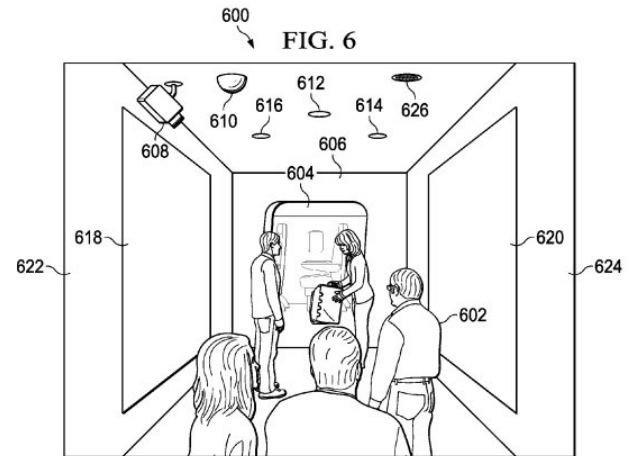

Infection disease detection by Boeing

patent process.

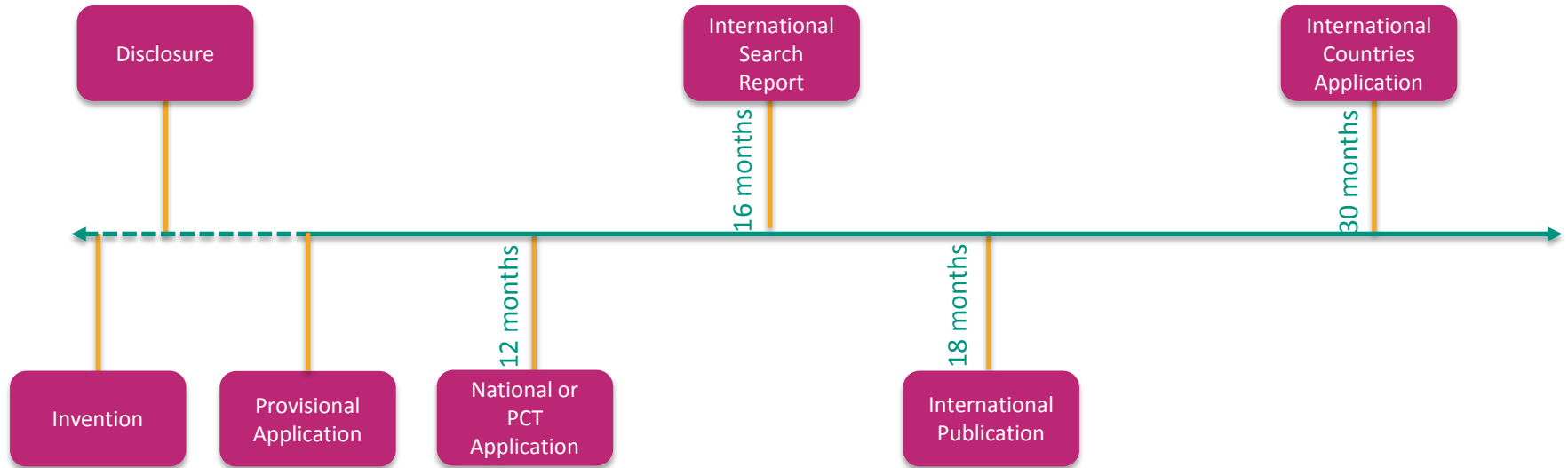

Protection for a maximum of 20 years from initial filing date

patent cost.

Filing Fee (CIPO):

\$400 (inventor filing)

\$6,000 - \$8,000 (patent agent)

PCT:

\$2,100 (inventors filing)

\$8,000 - \$15,000 (patent agent)

Maintenance Fees in Canada:

\$100 to \$450

Country-specific fees

**industrial
designs.**

what is an industrial design?

distinctive-looking features:

shape

pattern

ornament

normally provides a competitive edge

examples.

Dyson handheld vacuum
Canadian Industrial design: : 138957



The Coca Cola Bottle design patent
Serial Number: 73088384

MUNE musical instrument
Canadian Industrial design: 148812



iPhone 2014
Serial Number: 419391



trademarks™.

trademarks.

Words, sounds or designs that distinguishes a product or service

Protects corporate identity

Can be legally registered

rules.

Distinctive

Non-Deceptive

Arbitrary

examples.

FORD
Serial Number: 87230597

APPLE
Serial Number: 78170383

Twitter Logo
Serial Number: 86484982



Star Wars Lightsaber sound effect
Serial Number: 77419246



JUST DO IT

Nike Standard Character Mark
Serial Number: 86444421

Memorial University Design mark
Serial Number: 0917612



Google Logo
Serial Number: 86912587

tech transfer can help.

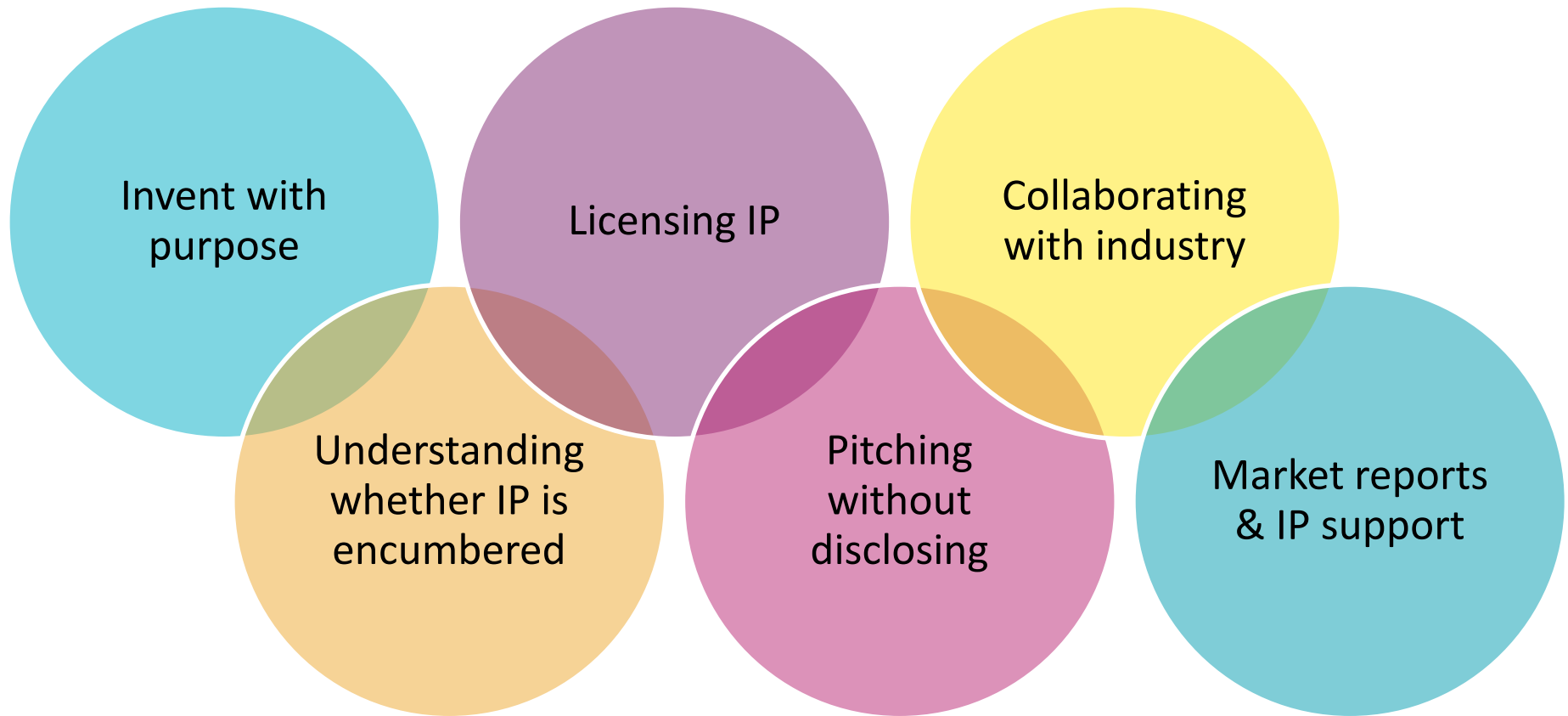

contact.

Dr. Paula Mendonça

Acting Director TTCO

mendonca@mun.ca

709-864-2674

Ms. Kara Strickland

IP Officer

Kara.Strickland@mun.ca

709-864-4466

 @MemorialTTCO

www.mun.ca/research/about/ttco/

